

# Pac West Supply LLC Gorilla Guard Ladder Cage Enclosure Installation Guide

[www.gorillaguardonline.com](http://www.gorillaguardonline.com)

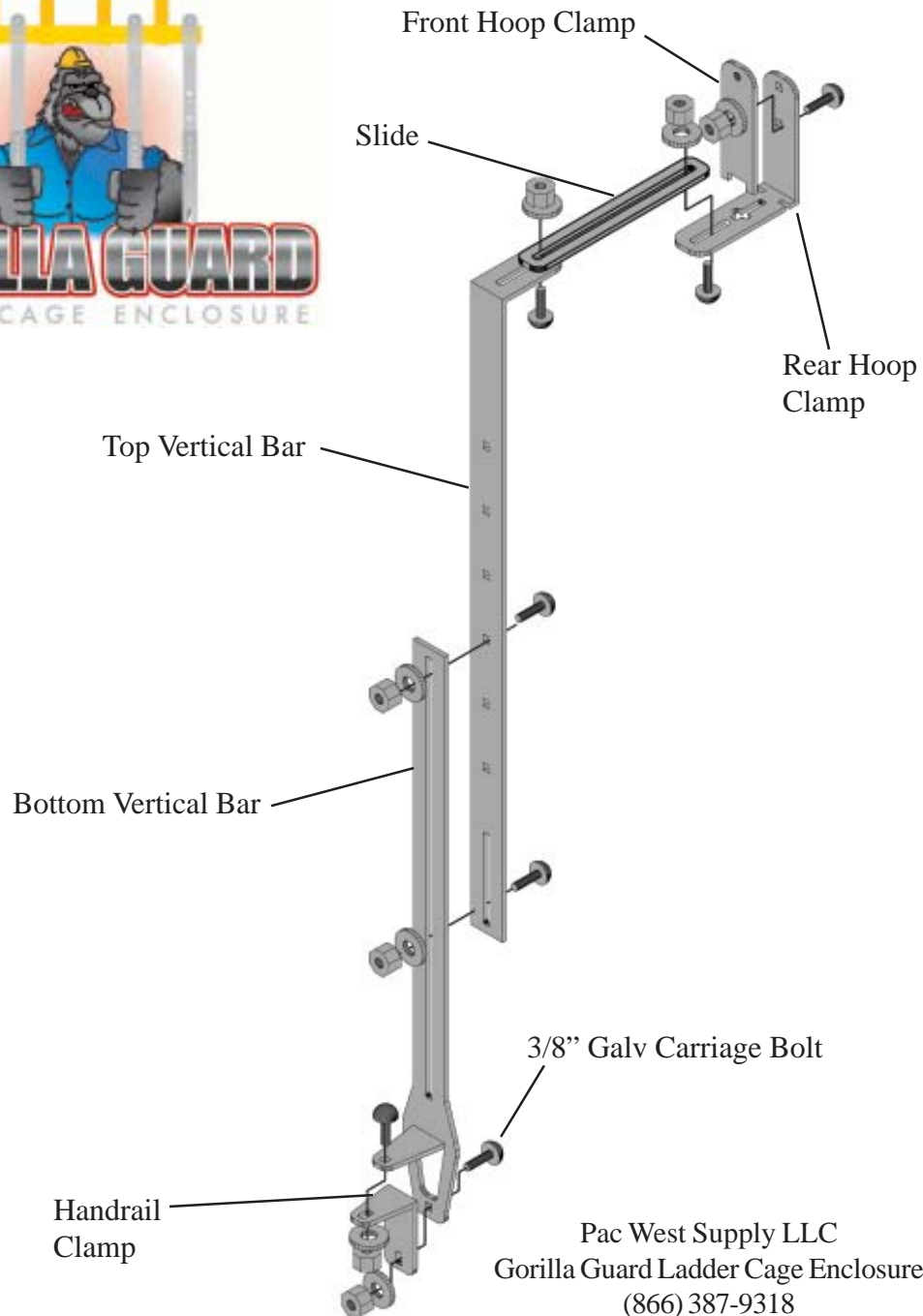

Pac West Supply LLC  
Gorilla Guard Ladder Cage Enclosure  
(866) 387-9318  
[info@gorillaguardonline.com](mailto:info@gorillaguardonline.com)

# Pac West Supply

## Gorilla Guard Ladder Cage Enclosure

### **Step 1-Installation of Bottom Vertical Bar**

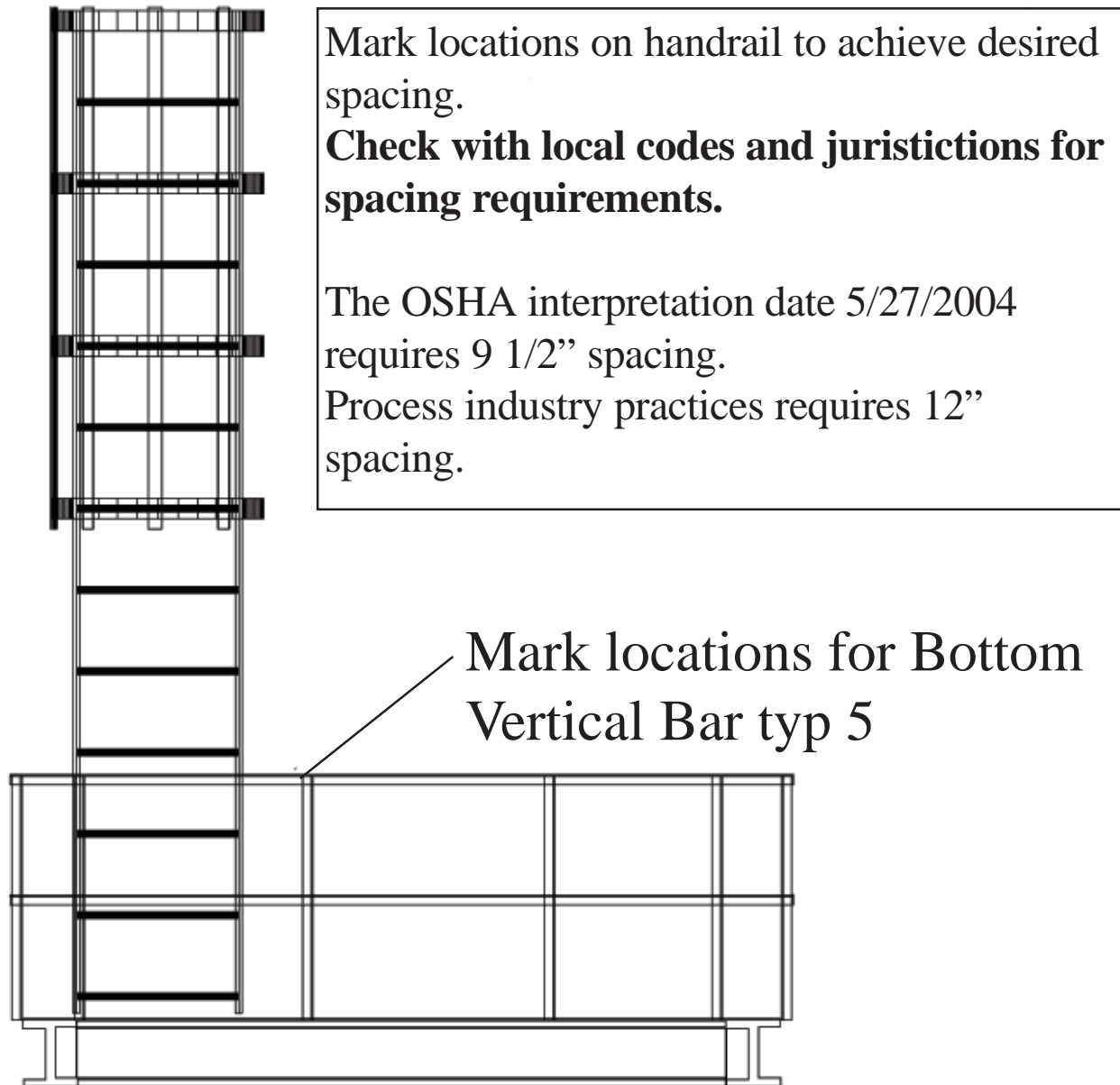

Pac West Supply LLC  
Gorilla Guard Ladder Cage Enclosure  
(866) 387-9318  
info@gorillaguardonline.com

# Gorilla Guard Ladder Cage Enclosure Installation Guide

## Step 1 Detail

1. Place bottom Vertical Bar on top of existing handrail.
2. Place handrail clamp underneath the existing handrail as shown below.
3. Install 2 ea 3/8" x 1.5" galvanized carriage bolts, nuts and washers.
3. Hand tighten only.

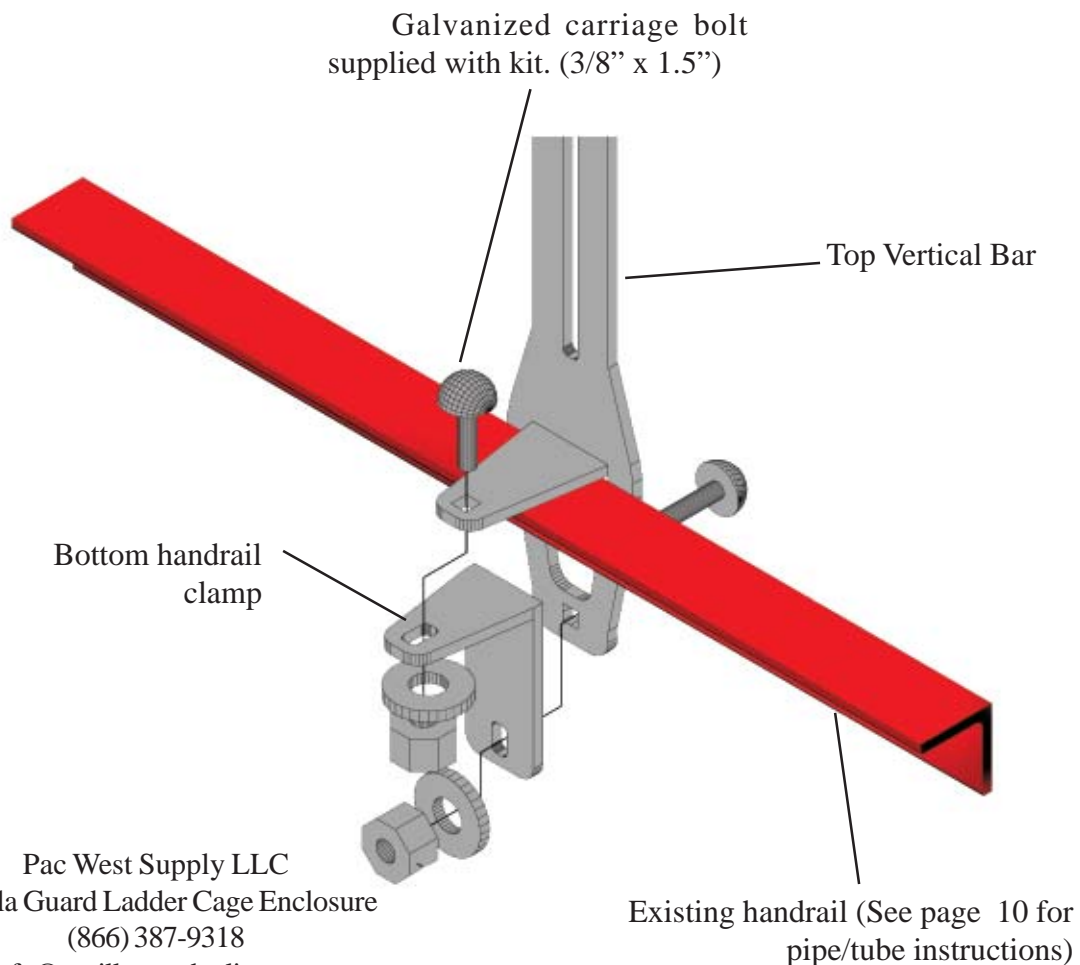

Pac West Supply LLC  
Gorilla Guard Ladder Cage Enclosure  
(866) 387-9318  
info@gorillaguardonline.com

# Pac West Supply

## Gorilla Guard Ladder Cage Enclosure

### Step 2

Mark locations for installation of cage hoop connections.  
Locations to be marked perpendicular to the Bottom Vertical Bars that were installed in step 1.

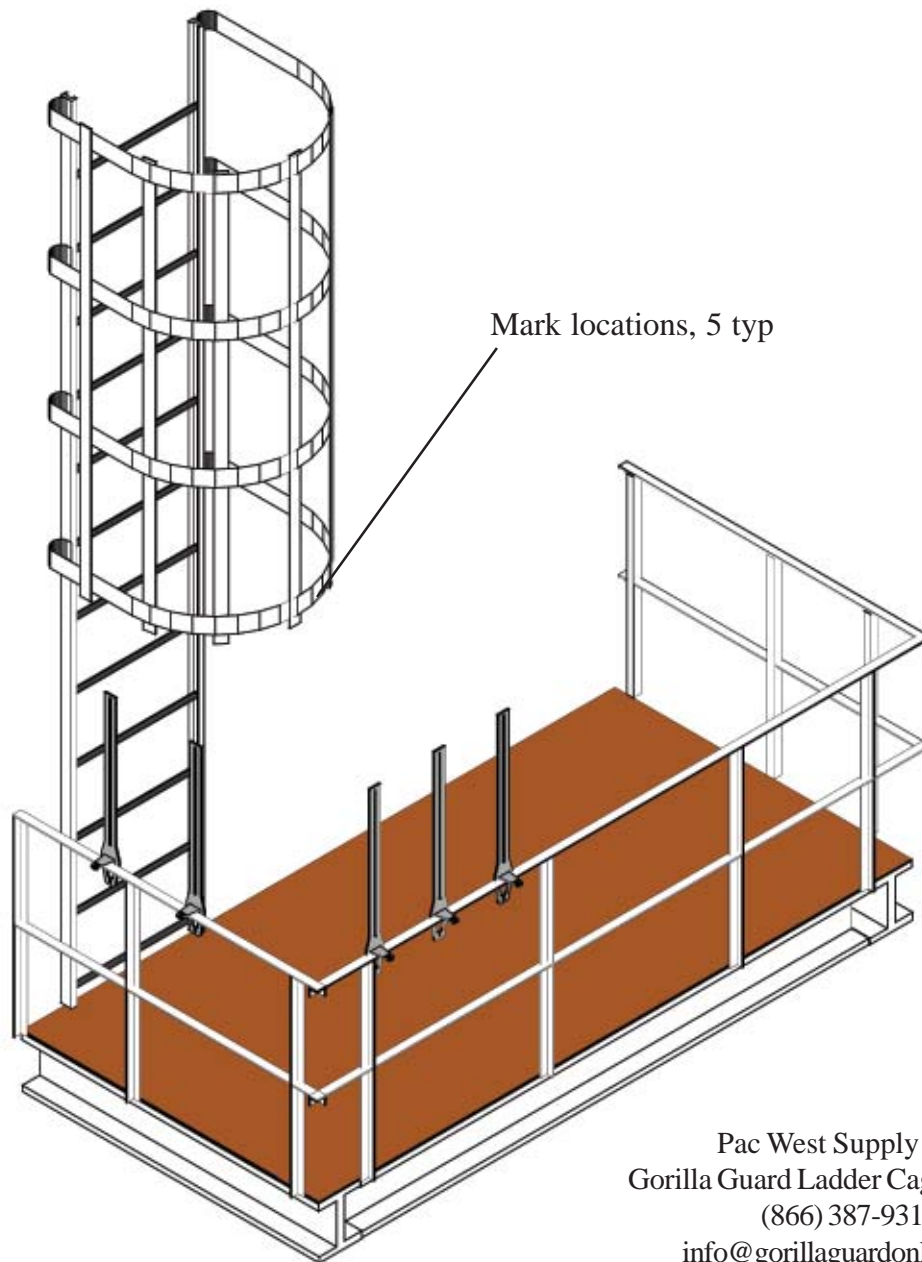

Pac West Supply LLC  
Gorilla Guard Ladder Cage Enclosure  
(866) 387-9318  
info@gorillaguardonline.com

# Gorilla Guard Ladder Cage Enclosure Installation Guide

## Step 2 Detail

1. Place Rear Hoop Clamp on the inner side of the lower hoop on the existing ladder cage.
2. Insert “legs” of Front Hoop Clamp into slots “A” of the rear hoop clamp.
3. Install carriage bolt as shown, hand tighten only.

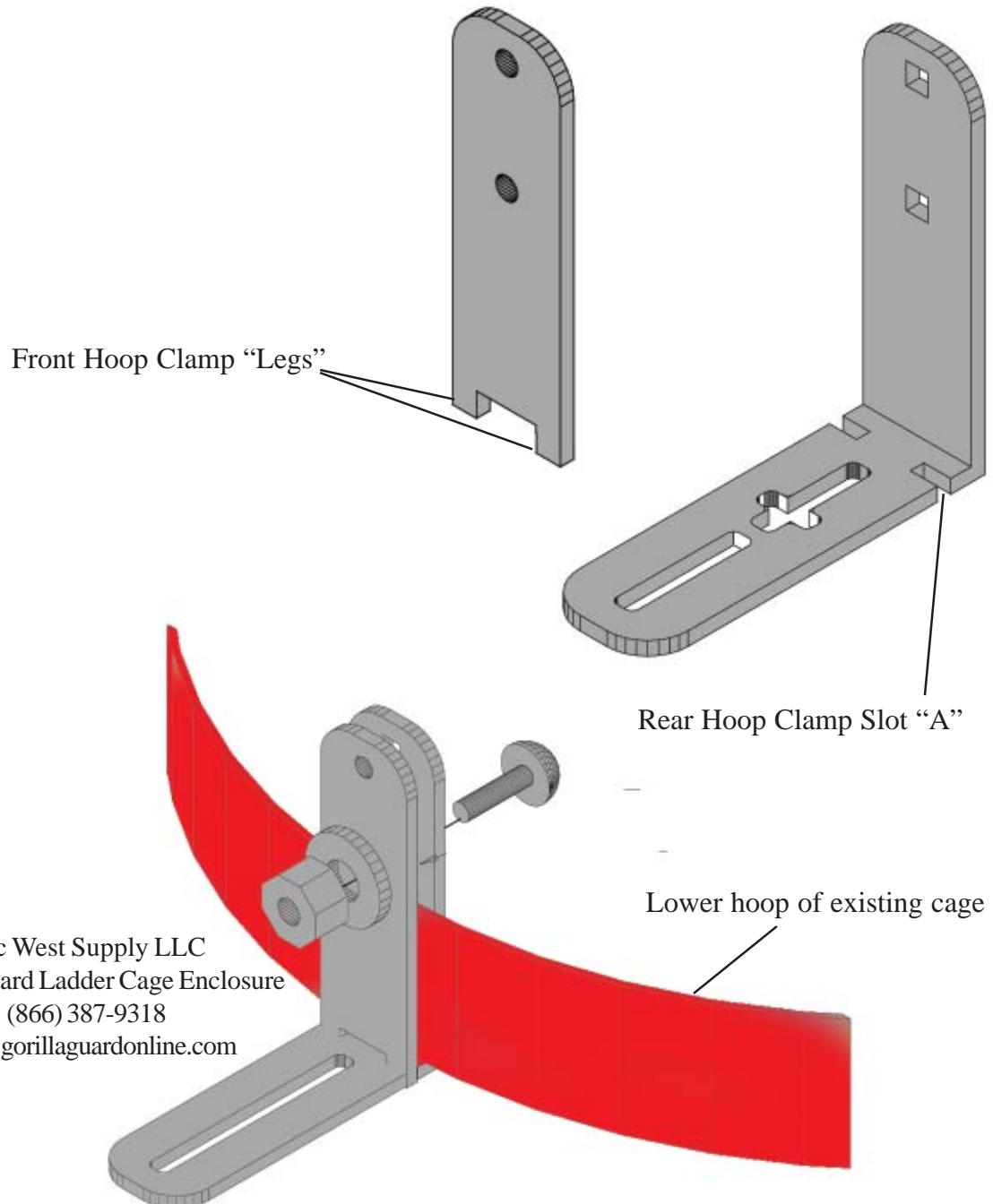

Pac West Supply LLC  
Gorilla Guard Ladder Cage Enclosure  
(866) 387-9318  
info@gorillaguardonline.com

Pac West Supply  
Gorilla Guard Ladder Cage Enclosure

Step 3 Top Vertical Bar Installation

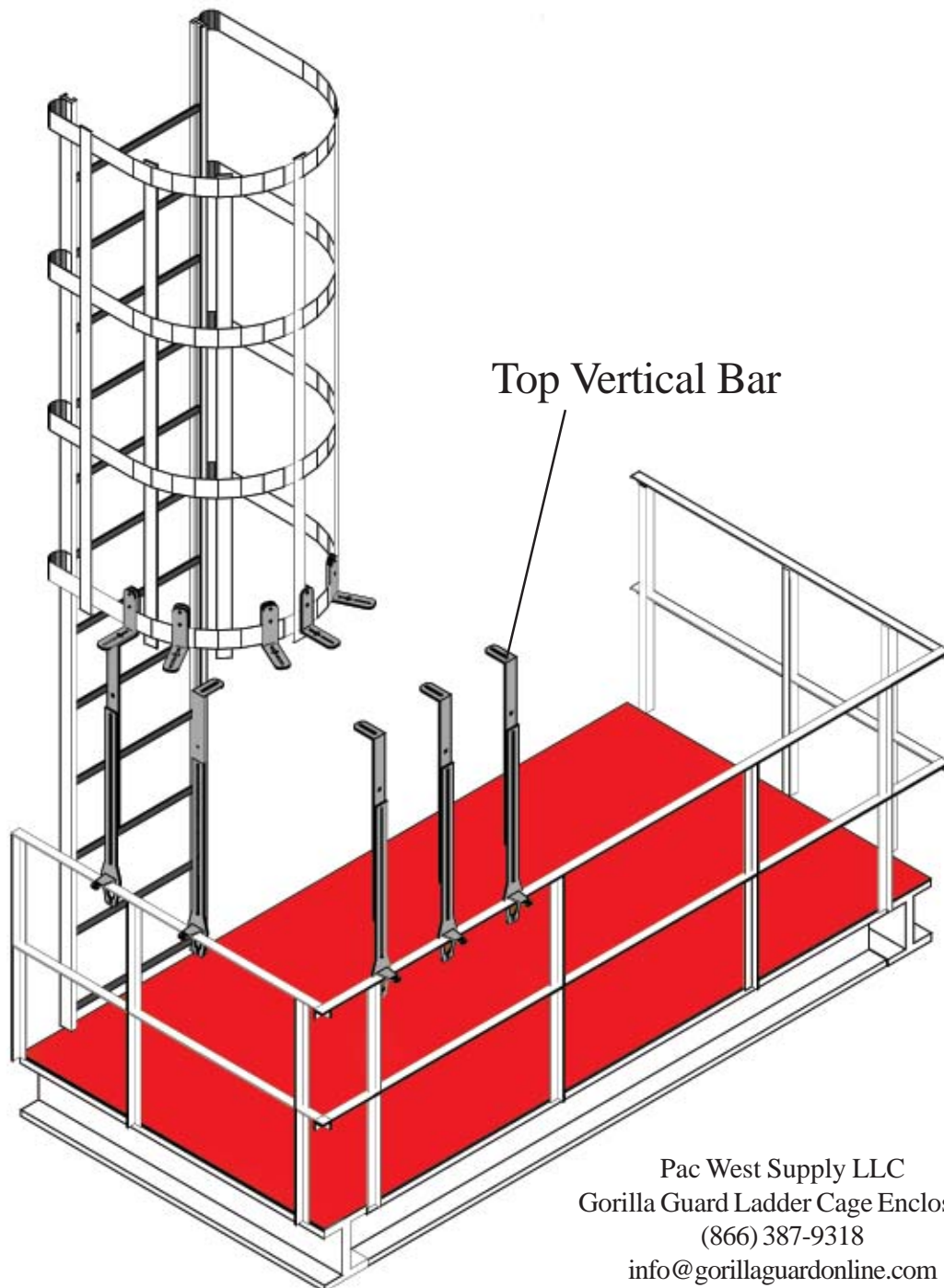

Pac West Supply LLC  
Gorilla Guard Ladder Cage Enclosure  
(866) 387-9318  
info@gorillaguardonline.com

## Step 3 Top Vertical Bar Installation Detail

1. Attach Top Vertical Bar using the supplied 2 ea 3/8" x 1.5" carriage bolts.
2. Elevation of the top bend of the vertical bar should match the elevation of the rear hoop clamp as installed in the previous step.
3. Hand tighten carriage bolts.

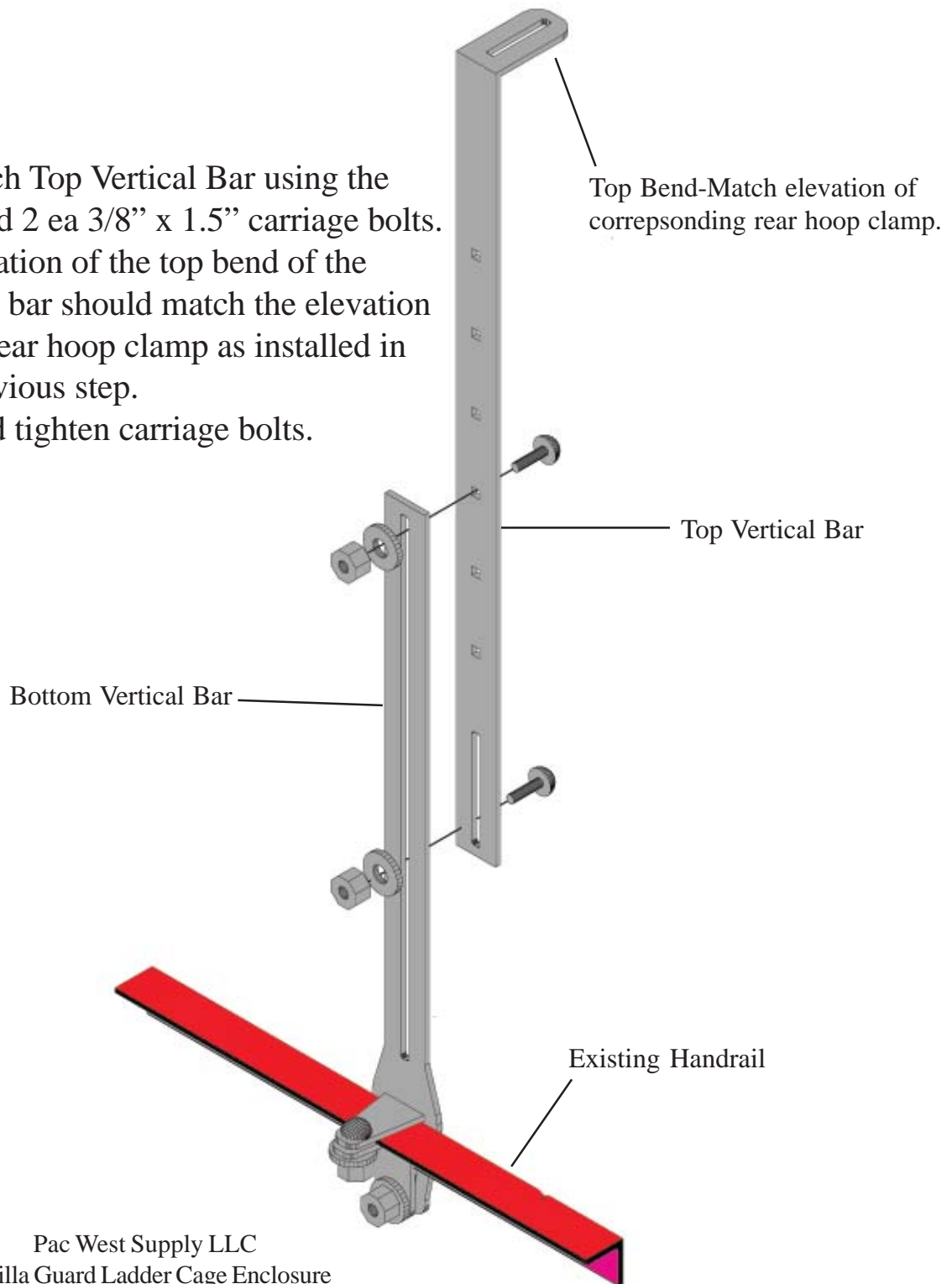

# Pac West Supply

## Gorilla Guard Ladder Cage Enclosure

### Step 4 Top Slide Installation

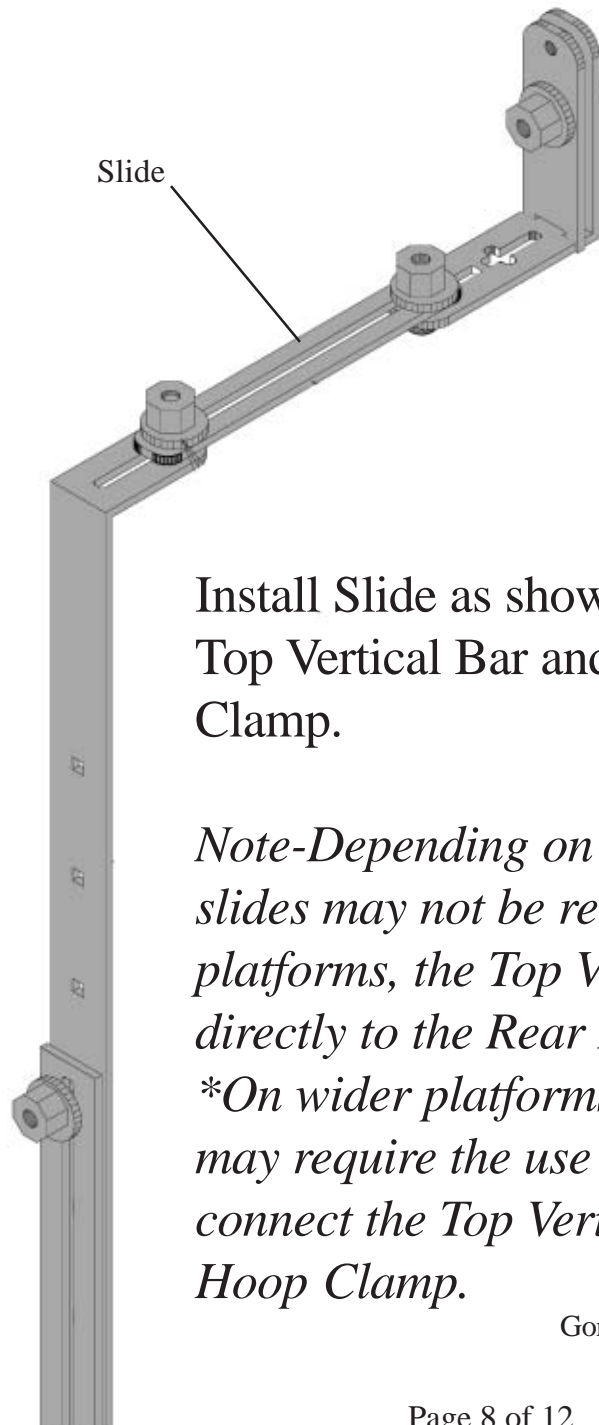

Install Slide as shown, connecting the Top Vertical Bar and the Rear Hoop Clamp.

*Note-Depending on the distance, some slides may not be required. On narrow platforms, the Top Vertical Bar will bolt directly to the Rear Hoop Clamp.*

*\*On wider platforms, some of the bars may require the use of two slides to connect the Top Vertical Bar to the Rear Hoop Clamp.*

Pac West Supply LLC  
Gorilla Guard Ladder Cage Enclosure  
(866) 387-9318  
info@gorillaguardonline.com



## Installation Completion

1. Adjust Top Vertical Bar and the slide to achieve level/plumb.
2. Torque all 3/8" galvanized carriage bolts 22-28 FT\*LBS
3. Ladder Cage Extensions, handrails, guards and similar numbers are not considered to be load bearing structures. At no time should these items be used as rigging points, tie off points or other circumstances that require an undesigned load.
4. The Universal Ladder Cage Extension Assembly should be included in a regular plant maintenance program, along with handrails, ladders and other safety equipment. Periodic checks for wear, corrosion, and fastener integrity should be performed on an annual basis.

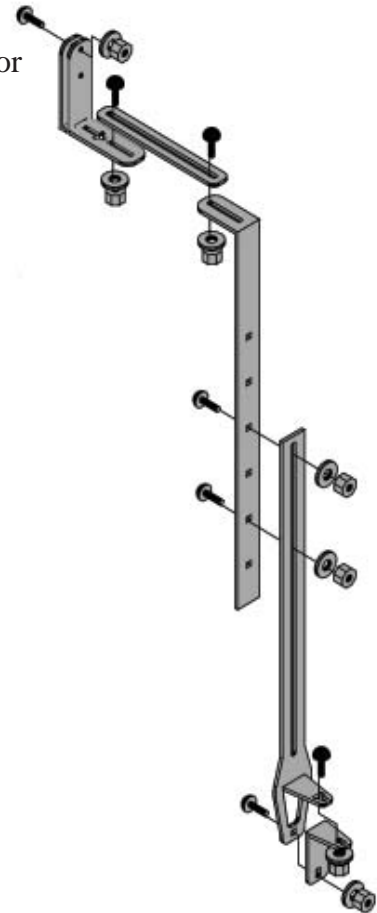
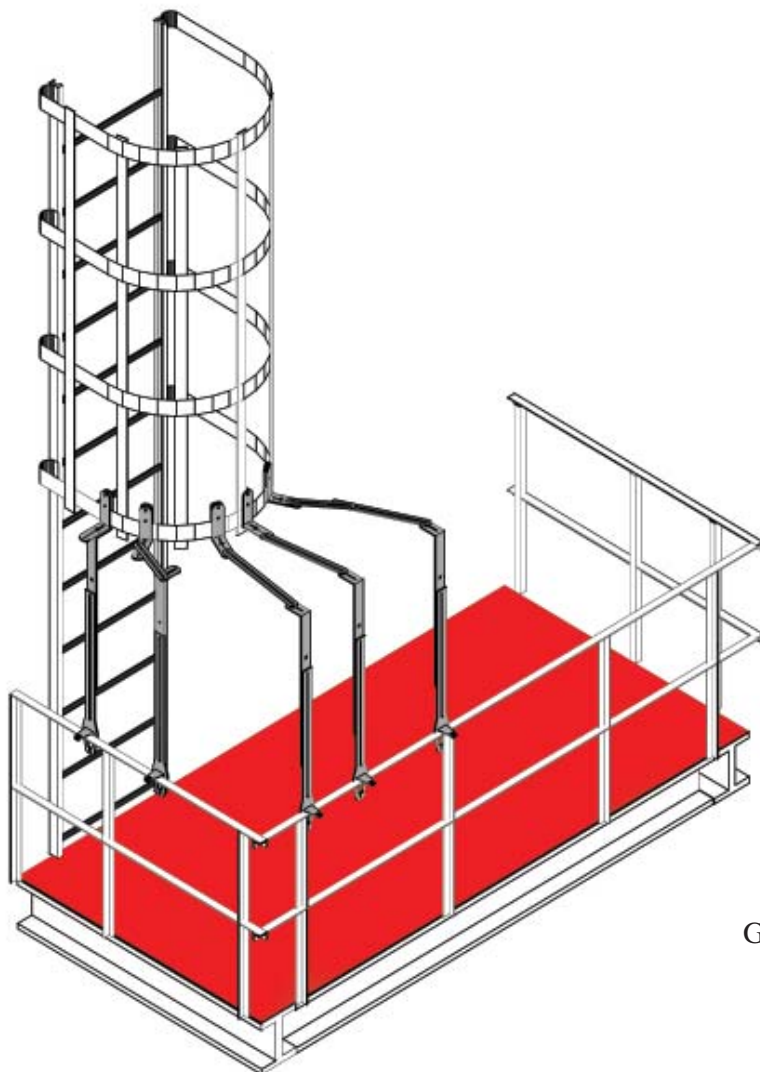

Pac West Supply LLC  
Gorilla Guard Ladder Cage Enclosure  
(866) 387-9318  
info@gorillaguardonline.com

# Pac West Supply

## Gorilla Guard Ladder Cage Enclosure

### Optional Pipe/Tube Adapter

The Pipe/Tube adapter can be used for handrail and cage applications.

Installation is identical for both the Bottom Vertical Bar and the Rear Hoop Clamp.

The Pipe/Tube adapter is designed for non-typical handrail and cage shapes such as pipe, tube, small channel, and extruded configurations.

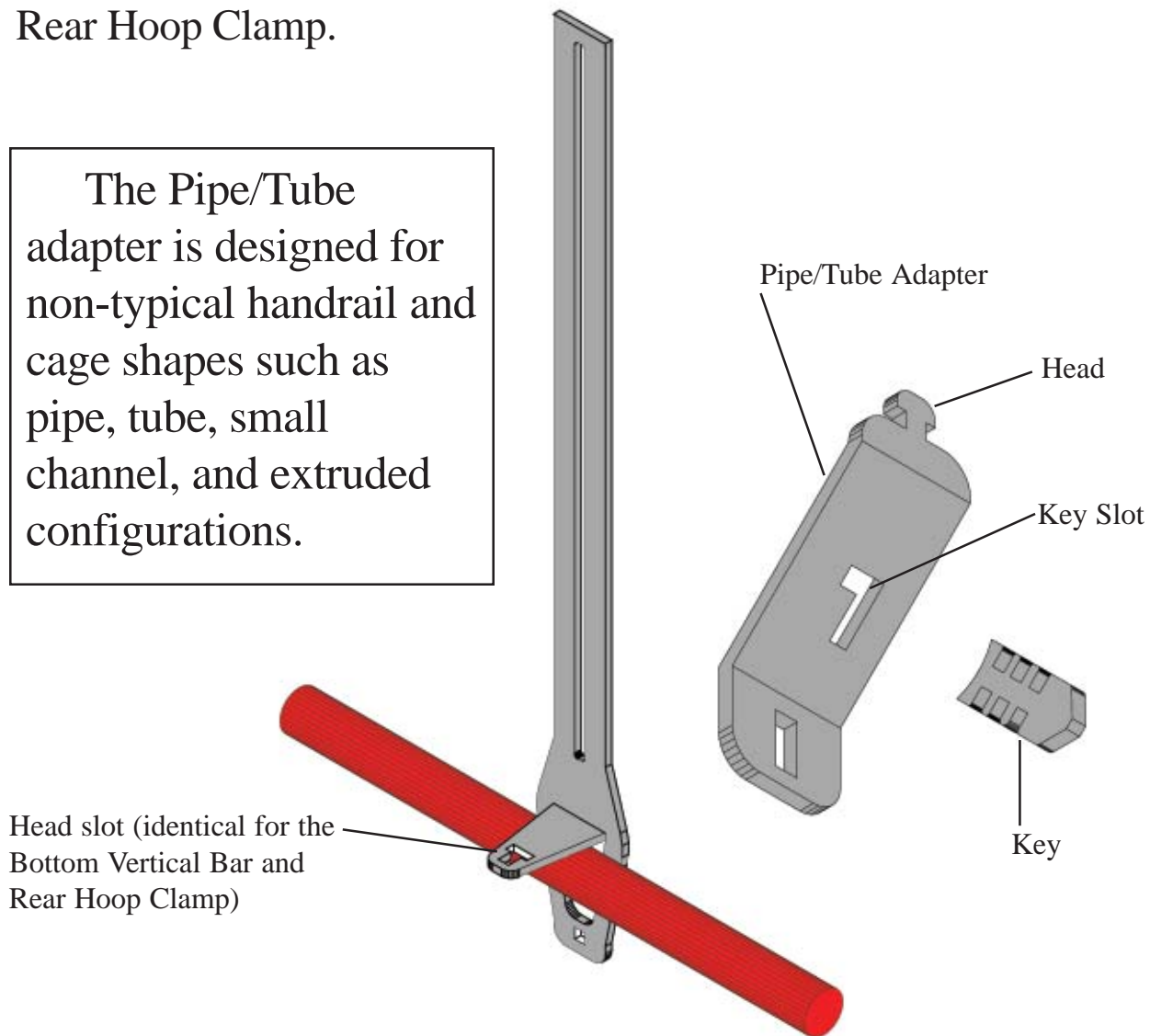

Pac West Supply LLC  
Gorilla Guard Ladder Cage Enclosure  
(866) 387-9318  
info@gorillaguardonline.com

# Gorilla Guard Ladder Cage Enclosure Installation Guide

1. Place Bottom Vertical Bar or Rear Hoop Clamp in proper location.
2. Insert head of Pipe/Tube adapter into the head slot of the Bottom Vertical Bar of the Rear Hoop Clamp. Insert Key into key slot to allow for a gap of 7/16" to 5/8" at location "A".
3. Install supplied 3/8" x 2" carriage bolt.
4. Torque 22-28 FT\*LBS

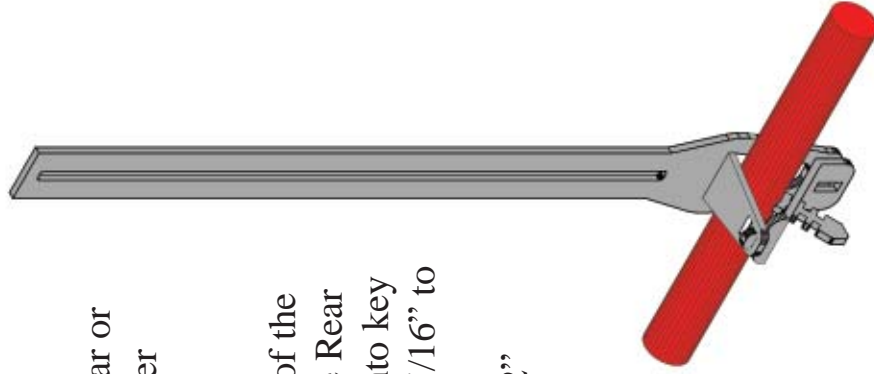
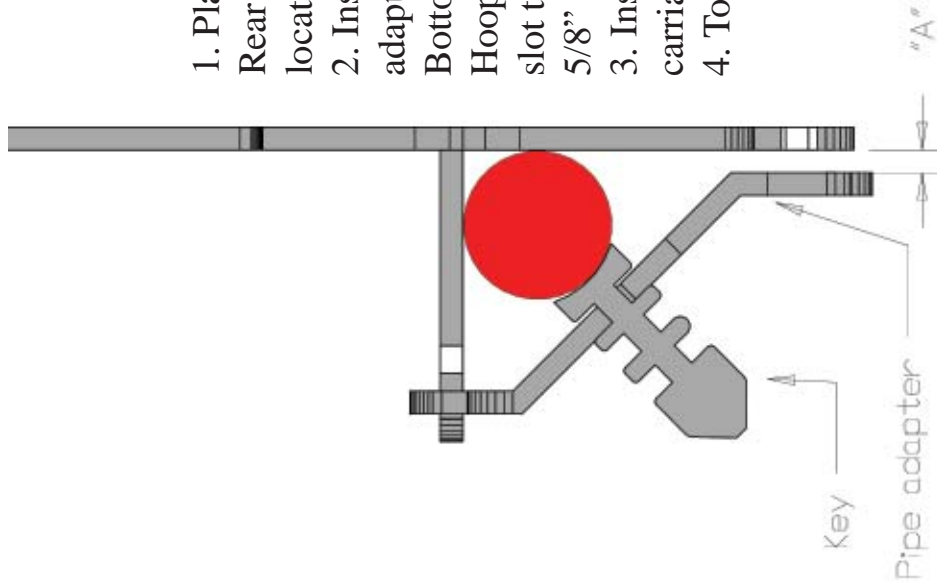

Pac West Supply LLC  
Gorilla Guard Ladder Cage Enclosure  
(866) 387-9318  
info@gorillaguardonline.com

# Gorilla Guard Ladder Cage Enclosure

## Pipe/Tube Adapter Detail

Pac West Supply LLC  
Gorilla Guard Ladder Cage Enclosure  
(866) 387-9318  
info@gorillaguardonline.com

Bottom Vertical Bar or Rear Hoop Clamp

Pipe adapter head

Existing handrail or cage  
hoop

Pipe/Tube Adapter

Key (Rotate key  
180 degrees for  
channel, angle or  
other non  
cylindrical shapes)

3/8" x 2" carriage  
bolt (supplied  
with kit)

